



TESTED AND COMMERCIAL CHAIN

1



Beaver's in depth range of tested and commercial chain suits a variety of applications. Our diverse range covers; stainless steel, general purpose, trailer safety chain, Grade 'L', Grade 80, Grade 100, Grade 120, proof coil and anchor chain. Beaver's consistency in providing a Quality Product to the Australian Market has been tried and tested, sourcing our products from the finest mills throughout the globe.



Contents

TESTED AND COMMERCIAL CHAIN

BEAVER REGULAR LINK PROOF COIL CHAIN	4
BEAVER LONG LINK PROOF COIL CHAIN	7
BEAVER GENERAL PURPOSE STAINLESS STEEL CHAIN	8
BEAVER GRADE 'L' CHAIN	10
BEAVER GRADE 'L' ANCHOR CHAIN	11
BEAVER TRAILER SAFETY CHAIN	12
BEAVER GRADE 50 STAINLESS STEEL LIFTING CHAIN	13
BEAVER GRADE 70 TRANSPORT CHAIN	14
BEAVER GRADE 80 (T) LIFTING CHAIN - B-ALLOY	15
BEAVER GRADE 80 FISHING LINE CHAIN	16
BEAVER GRADE 100 LIFTING CHAIN	17
BEAVER HEAVY DUTY PLASTIC CHAIN	18
BEAVER CALIBRATED LOAD CHAIN	19
PRODUCT REFERENCE GUIDE	20

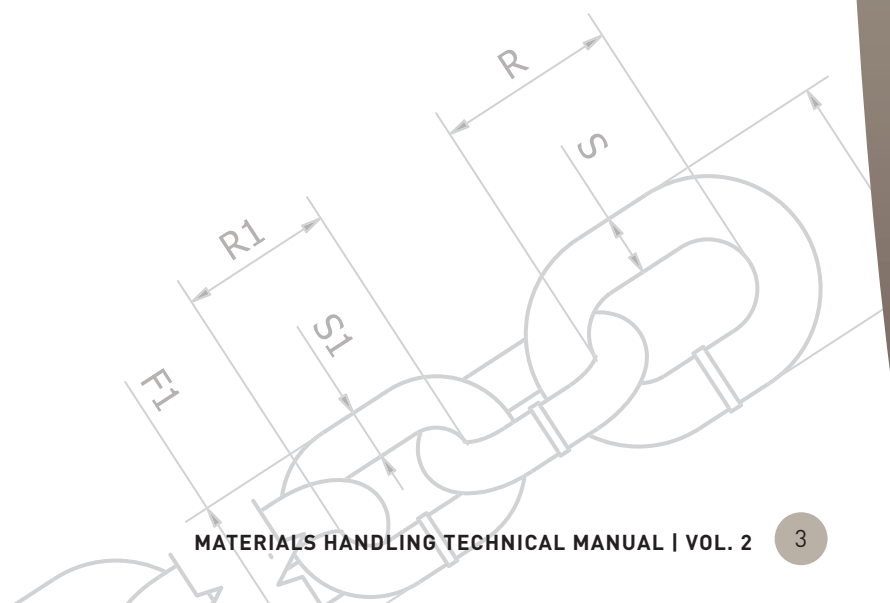



BEAVER REGULAR LINK PROOF COIL CHAIN



Beaver Regular Link Proof Coil Commercial Chain

Beaver Proof Coil Commercial Chain is a non-rated chain, manufactured from low carbon steel and is for general purpose use only. "Proof coil" relates to the number of consistent links in any one length.

- Not Suitable for any lifting purposes.
- Lengths include – regular link and long link
- Available in Hot Dipped Galvanised, Electro Galvanised and Self Colour

Beaver Regular Link Proof Coil Chain

Hot Dipped Galvanised – Sizes 3 - 24mm

Code	Nominal Size mm	S mm	R mm	F mm	Finish	UOM	Metres Per 100(kg)
100303	3	3.2	16	12	Galvanised	Metre	498
100304	4	4	18.5	14.5	Galvanised	Metre	305
100305	5	4.7	19	17	Galvanised	Metre	193
100306	6	6.35	22	21	Galvanised	Metre	120
100308	8	7.94	26.5	27.2	Galvanised	Metre	74.1
100310	10	9.5	30	32	Galvanised	Metre	47.1
100313	13	12.7	39	43	Galvanised	Metre	27.7
100316	16	15.8	45	53	Galvanised	Metre	18.2
100320	20	19	55	63	Galvanised	Metre	11.6
100324	24	25.4	73	84	Galvanised	Metre	8.04

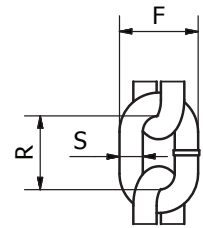

Metres per drum are subject to + or - 10% on actual metrage

NOT TO BE USED FOR LIFTING

Beaver Regular Link Proof Coil Chain

Self Colour – Sizes 3 - 24mm

Code	Nominal Size mm	S mm	R mm	F mm	Finish	UOM	Metres Per 100(kg)
100103	3	3.2	16	12	Self Colour	Metre	511
100104	4	4	18.5	14.5	Self Colour	Metre	320
100105	5	4.7	19	17	Self Colour	Metre	203
100106	6	6.35	22	21	Self Colour	Metre	129
100108	8	7.94	26.5	27.2	Self Colour	Metre	77.8
100110	10	9.5	30	32	Self Colour	Metre	48.5
100113	13	12.7	39	43	Self Colour	Metre	29.7
100116	16	15.8	45	53	Self Colour	Metre	20.2
100120	20	19	55	63	Self Colour	Metre	12.3
100124	24	25.4	73	84	Self Colour	Metre	8.5

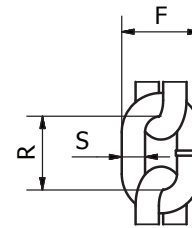

Metres per drum are subject to
+ or - 10% on actual metrage

**NOT TO BE USED
FOR LIFTING**

Customised Beaver Proof Coil Chain

Sizes 4 - 8mm

Code	Nominal Size mm	Finish	UOM	Length Metres
100304-VTC-AC	4	Hot Dipped Galvanised	Metre	3.1
100206-2.5	6	Electro Galvanised	Metre	2.5
100206-1.2	6	Electro Galvanised	Metre	1.2
130206-2.5	6	Electro Galvanised	Metre	2.5
130308-1.5	8	Electro Galvanised	Metre	1.5
130206-1.5	8	Hot Dipped Galvanised	Metre	1.5

Above are held on stock at customer's request.
Beaver can design for every application. eg. underground vent tube chain, conveyor hanging chain, etc.

**NOT TO BE
USED FOR
LIFTING**

BEAVER REGULAR LINK PROOF COIL CHAIN (CONT'D)

Beaver Regular Link Hardware Chain

Pre-Packed 50kg Handy Hardware Display Pail

Code	Size mm	UOM	Metres Per 50(kg)	Finish
100103PP	3	Pail	256	Self Colour
100203PP	3	Pail	249	Electro Galvanised
100303PP	3	Pail	249	Galvanised
100104PP	4	Pail	160	Self Colour
100304PP	4	Pail	170	Galvanised
100105PP	5	Pail	102	Self Colour
100305PP	5	Pail	97	Galvanised
100106PP	6	Pail	64.5	Self Colour
100306PP	6	Pail	60	Galvanised
100108PP	8	Pail	39	Self Colour
100308PP	8	Pail	37	Galvanised
100110PP	10	Pail	24.3	Self Colour
100310PP	10	Pail	23.6	Galvanised
100113PP	13	Pail	14.85	Self Colour
100313PP	13	Pail	13.8	Galvanised



Metres per pail are subject to + or - 10% on actual metreage

**NOT TO BE USED
FOR LIFTING**

BEAVER LONG LINK PROOF COIL CHAIN

Beaver Long Link Proof Coil Chain

Hot Dipped Galvanised – Sizes 4 - 10mm

Code	Nominal Size mm	S mm	R mm	F mm	Finish	UOM	Metres Per 100(kg)
130304	4	4	25.4	18.6	Galvanised	Metre	318
130305	5	5	29.3	21.8	Galvanised	Metre	206
130306	6	6.3	34.5	26.1	Galvanised	Metre	128
130308	8	8	41.2	31.9	Galvanised	Metre	78.1
130310	10	10	49	38	Galvanised	Metre	50.2

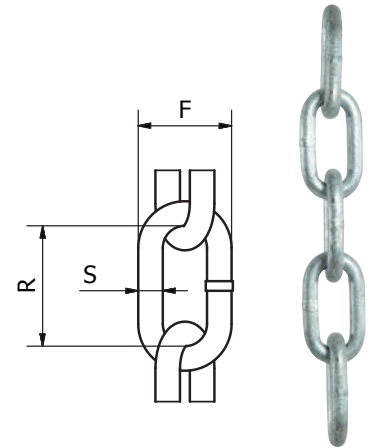

Metres per drum are subject to + or - 10% on actual metrage **NOT TO BE USED FOR LIFTING**

Beaver Long Link Proof Coil Chain

Self Colour – Sizes 4 - 10mm

Code	Nominal Size mm	S mm	R mm	F mm	Finish	UOM	Metres Per 100(kg)
130104	4	4	25.4	18.6	Self Colour	Metre	335
130105	5	5	29.3	21.8	Self Colour	Metre	217
130106	6	6.3	34.5	26.1	Self Colour	Metre	135
130108	8	8	41.2	31.9	Self Colour	Metre	82.2
130110	10	10	49	38	Self Colour	Metre	52.9

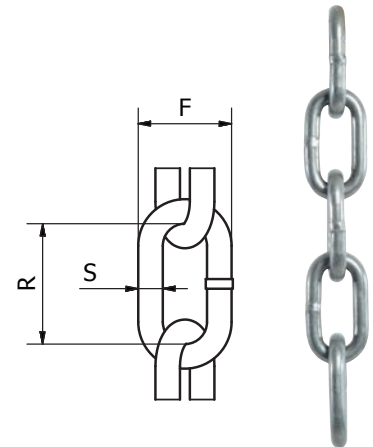

Metres per drum are subject to + or - 10% on actual metrage **NOT TO BE USED FOR LIFTING**

Beaver Long Link Proof Coil Chain

Electro Galvanised – Sizes 5 - 8mm

Code	Nominal Size mm	S mm	R mm	F mm	Finish	UOM	Metres Per 100(kg)
130205	5	5	29.3	21.8	Electro Gal	Metre	206
130206	6	6.3	34.5	26.1	Electro Gal	Metre	128
130208	8	8	41.2	31.9	Electro Gal	Metre	78.1

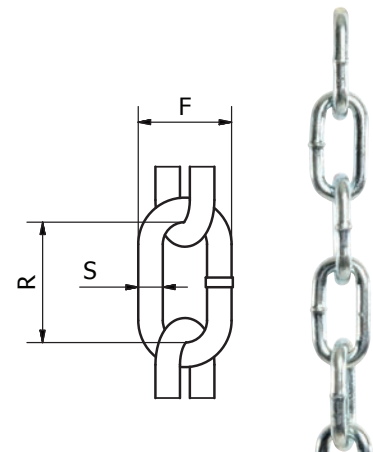

Metres per drum are subject to + or - 10% on actual metrage **NOT TO BE USED FOR LIFTING**

BEAVER GENERAL PURPOSE STAINLESS STEEL CHAIN



Beaver Stainless Steel General Purpose Chain

Beaver General Purpose Stainless Steel Chain, manufactured in 304 and 316 grade stainless steel.

- Not Suitable for any lifting or towing purposes
- Lengths include – short link, regular link and long link
- For Stainless Steel Lifting Chain – refer to Grade 50 Stainless Steel Chain

Beaver Grade 304 Stainless Steel Chain

Regular Link – Sizes 4 - 10mm

Code	Nominal Size mm	S mm	R mm	F mm	Finish	UOM	Metres Per 100(kg)
147104	4	4	18.6	16	Stainless Steel	Metre	384.6
147106	6	6	26	23.5	Stainless Steel	Metre	137.3
147108	8	8	32.2	29.5	Stainless Steel	Metre	80
147110	10	10	39	36.2	Stainless Steel	Metre	49.6

Metres per drum are subject to + or - 10% on actual metrage

NOT TO BE USED FOR LIFTING

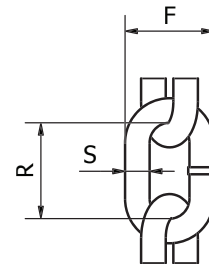

Beaver Grade 316 Stainless Steel Chain

Regular Link – Sizes 2 - 13mm

Code	Nominal Size mm	S mm	R mm	F mm	Finish	UOM	Metres Per 100(kg)
146102	2	2	14.8	8.25	Stainless Steel	Metre	1666.6
146104	4	4	18.6	16	Stainless Steel	Metre	384.6
146106	6	6	26	23.5	Stainless Steel	Metre	137.3
146108	8	8	32.2	29.5	Stainless Steel	Metre	80
146110	10	10	39	36.2	Stainless Steel	Metre	49.6
146113	13	13	49.1	46.1	Stainless Steel	Metre	28.7

Metres per drum are subject to + or - 10% on actual metrage

NOT TO BE USED FOR LIFTING

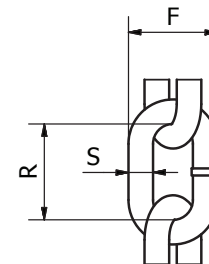

Beaver Grade 316 Stainless Steel Chain

Short Link – Sizes 4 - 8mm

Code	Nominal Size mm	S mm	R mm	F mm	Finish	UOM	Metres Per 100(kg)
146206	6	6	30.5	19.2	Stainless Steel	Metre	133.3
146208	8	8	40	25.6	Stainless Steel	Metre	74.8

Metres per drum are subject to + or - 10% on actual metrage

NOT TO BE USED FOR LIFTING

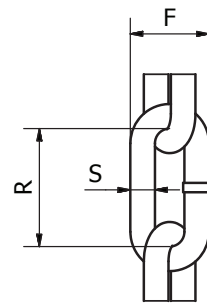

Beaver Grade 316 Stainless Steel Chain

Long Link

Code	Nominal Size mm	S mm	R mm	F mm	Finish	UOM	Metres Per 100(kg)
146102L	2	2	26	8	Stainless Steel	Metre	1639

Metres per drum are subject to + or - 10% on actual metrage

NOT TO BE USED FOR LIFTING

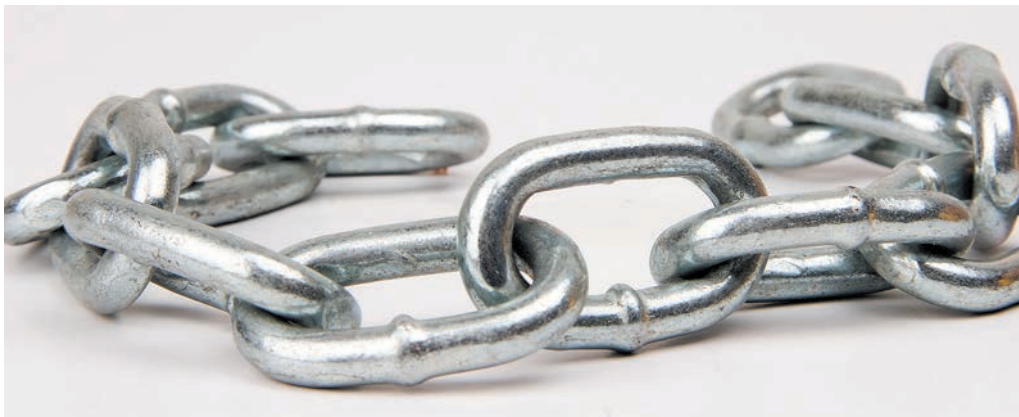
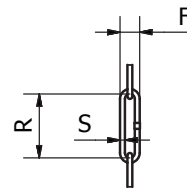

BEAVER GRADE 'L' CHAIN



Beaver Grade 'L' Chain

Beaver Grade 'L' Chain complies with the requirements of Australian Standard AS 2321 Short-Link Chain for Lifting Purposes. Manufactured from Grade 30 low carbon steel and is commonly used for moorings, anchor chain and other marine applications.

➤ Available in Galvanised and Self Colour finishes

Beaver Short Link Grade 'L' Chain To AS 2321

Self Colour – Sizes 6 - 10mm

Code	W.L.L Tonne	Nominal Size mm	S mm	R mm	F mm	Finish	UOM	Metres Per 100(kg)
143106	0.40	6	6.3	18.8	21.6	Self Colour	Metre	116.3
143108	0.64	8	8	23.8	27	Self Colour	Metre	71
143110	1.00	10	10	29.8	34.3	Self Colour	Metre	45

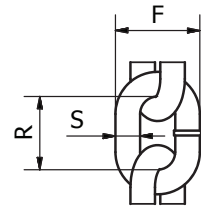

Metres per drum are subject to + or - 10% on actual metreage

NOT RECOMMENDED FOR LIFTING

Beaver Short Link Grade 'L' Chain To AS 2321

Hot Dipped Galvanised – Sizes 6 - 20mm

Code	W.L.L Tonne	Nominal Size mm	S mm	R mm	F mm	Finish	UOM	Metres Per 100(kg)
143306	0.40	6	6.3	18.8	21.6	Galvanised	Metre	110
143308	0.64	8	8	23.8	27	Galvanised	Metre	69.9
143310	1.00	10	10	29.8	34.3	Galvanised	Metre	43.9
143313	1.70	13	13	38.8	44.6	Galvanised	Metre	26.3
143316	2.58	16	16	47.8	54.8	Galvanised	Metre	17.5
143320	4.03	20	20	59.2	68.5	Galvanised	Metre	11.1

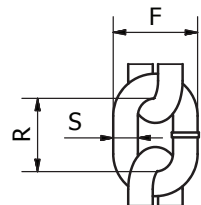

Metres per drum are subject to + or - 10% on actual metreage

NOT RECOMMENDED FOR LIFTING

BEAVER GRADE 'L' ANCHOR CHAIN



Beaver Grade 'L' Anchor Chain (Fathom Chain)

Beaver Grade 'L' Anchor Chain commonly referred to as Fathom Chain, is used in heavy duty marine applications, such as anchors and mooring lines.

► Comes complete with enlarged link at each end

Beaver Grade 'L' Anchor Chain (Galvanised)

Short Link – 110 metre lengths c/w enlarged link each end

Code	Chain Size (S1) mm	Chain (F1) mm	Chain (R1) mm	Endlink F	Endlink S	Endlink R	Finish	UOM	Length m	MWL Tonne
143313A	13	45	39	46	16	57	Galvanised	Length	110	2.1
143316A	16	55	47	58	20	69	Galvanised	Length	110	3.2

Metres per drum are subject to + or - 10% on actual metrage

NOT RECOMMENDED FOR LIFTING

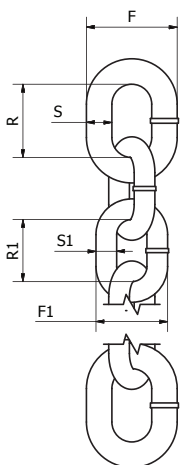



BEAVER TRAILER SAFETY CHAIN



Beaver Trailer Safety Chain

Beaver Trailer Safety Chain is designed in accordance with Australian/New Zealand AS/NZS 4177.4. It is manufactured for the use of coupling towed devices such as trailers. Refer to applicable state for rules & regulations.

➤ Available in Hot Dipped Galvanised and Self Colour Finishes

Beaver - Trailer Safety Chain – to AS/NZS 4177.4

Self Colour and Galvanised High Tensile – Size 8 - 13mm

For trailers up to 3500kg ATM

Code	W.L.L Tonne	Nominal Size mm	S mm	R mm	F mm	Finish	UOM	Metres Per 100(kg)
142008	1.60	8	7.6	43.5	31	Self Colour	Metre	93.4
142008G	1.60	8	7.6	43.5	31	Galvanised	Metre	91.1
142010	2.50	10	9.5	53.1	39	Self Colour	Metre	61.2
142010G	2.50	10	9.5	53.1	39	Galvanised	Metre	59.7
142013	3.50	13	12	51.7	44.5	Self Colour	Metre	65.5
142013G	3.50	13	12	51.7	44.5	Galvanised	Metre	34.6

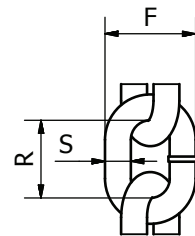

Trailer Safety Chain is not suitable for lifting purposes.
Metres per drum are subject to + or - 10% on actual metrage

**NOT TO BE USED
FOR LIFTING**



BEAVER GRADE 50 STAINLESS STEEL LIFTING CHAIN



Beaver Grade 50 Stainless Steel Lifting Chain

Beaver Grade 50 Stainless Steel Lifting Chain is manufactured from Grade 316 stainless steel and is tested in accordance with Australian Standard AS 4797. It's high corrosive resistant properties make it ideal for lifting in environments such as water treatment plants, waste management and food processing.

- Beaver Grade 50 Chain carries the mark "PWG5", stamped on every link along its entire length for easy identification

Grade 50 Stainless Steel Lifting Chain G316 – to AS 4797

Stainless Steel – Load Rated – Size 5 – 16mm

Code	W.L.L Tonne	Nominal Size mm	S mm	R mm	F mm	Finish	UOM	Metres Per 100(kg)
WOX5	0.50	5	5	16	17.5	Stainless Steel	Metre	178
WOX7	1.00	7	7	21	23.53	Stainless Steel	Metre	90
WOX10	2.00	10	10	30	33.5	Stainless Steel	Metre	45
WOX13	3.20	13	13	39	43.5	Stainless Steel	Metre	26

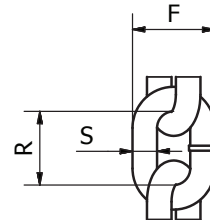

Metres per drum are subject to + or - 10% on actual metreage



BEAVER GRADE 70 TRANSPORT CHAIN



Beaver Grade 70 Transport Chain

Beaver Transport Chain is manufactured from heat treated carbon steel, in accordance with Australian/New Zealand AS/NZS 4344 - Transport Chain and Components. Transport Chain is primarily used in lashing applications to tie down loads on transport equipment.

- The yellow zinc dichromate (gold) plating makes it easily recognizable even from a distance
- Beaver transport chain also carries the mark 4344 plus the chain capacity, stamped at intervals along its entire length
- Is NOT for lifting

Beaver Grade 70 Transport Chain – to AS/NZS 4344

“Gold” High Tensile – Sizes 6 - 13mm

Code	Lashing Capacity Tonne	Nominal Size mm	S mm	R mm	F mm	Finish	UOM	Metres Per 100(kg)
145006	2.30	6	6	18.5	20	Zinc Dichromate	Metre	125
145007	3.00	7	7	22	24	Zinc Dichromate	Metre	92
145008	3.80	8	8	24	28	Zinc Dichromate	Metre	70
145010	6.00	10	10	30	35	Zinc Dichromate	Metre	45
145013	9.00	13	13	39	45.5	Zinc Dichromate	Metre	26.8

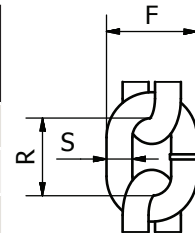

Metres per drum are subject to + or - 10% on actual metreage

NOT TO BE USED FOR LIFTING

BEAVER GRADE 80 (T) LIFTING CHAIN – B-ALLOY



Beaver Grade 80 (T) Lifting Chain

Beaver Grade 80 (T) Chain, manufactured from heat treated alloy steel and is ideal for heavy duty lifting applications. It meets Australian standards AS 2321, Short-Link Chain for Lifting Purposes. It is high strength, rugged, versatile and low-weight.

- Quality testing is done throughout the manufacturing process
- Beaver Grade 80 Chain also carries markings in accordance with Australian standards, stamped at intervals along its entire length for easy identification

Grade T(80) Alloy Chain – to AS 2321

Load Rated – 6 - 32mm

Code	W.L.L Tonne	Nominal Size mm	S mm	R mm	F mm	Finish	UOM	Metres Per 100(kg)
148006	1.20	6	6	18	22.2	Self Colour	Metre	115
148007	1.60	7	7	21	25.9	Self Colour	Metre	90
148008	2.00	8	8	24	29.6	Self Colour	Metre	71
148010	3.20	10	10	30	37	Self Colour	Metre	45
148013	5.40	13	13	39	48.1	Self Colour	Metre	26
148016	8.20	16	16	48	59.2	Self Colour	Metre	17
148020	12.8	20	20	60	74	Self Colour	Metre	11
148022	16.00	22	22	66	81.4	Self Colour	Metre	9
148026	20.60	26	26	78	96.2	Self Colour	Metre	6
148032	31.50	32	32	96	118	Self Colour	Metre	4

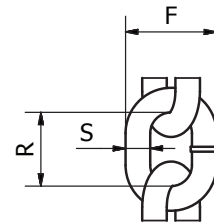

Metres per drum are subject to + or - 10% on actual metrage



BEAVER GRADE 80 FISHING LINE CHAIN



Beaver Grade 80 Fishing Line Chain

Beaver Grade 80 Fishing Line Chain is a long link chain for commercial fishing applications. It comes painted yellow for corrosive resistance and to improve visibility.

Beaver Alloy Grade 80 Fishing line Chain (painted yellow)

Long Link – Sizes 9 - 16mm

Code	W.L.L Tonne	Nominal Size mm	S mm	R mm	F mm	Finish	UOM	Metres Per 100(kg)
130411	3.90	11	11	64	40	Yellow Paint	Metre	47.62

Metres per drum are subject to + or - 10% on actual metrage

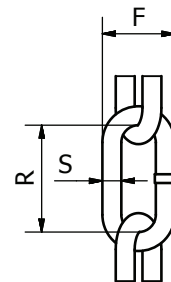

**NOT TO BE USED
FOR LIFTING**



BEAVER GRADE 100 LIFTING CHAIN



Beaver Grade 100 Lifting Chain

Beaver Grade 100 Lifting Chain is sourced entirely from Europe and the world's leading manufacturers. Our Grade 100 chain complies with European Standard EN 818-2 and is tested in accordance with Australian Standard AS 2321.

- It's rugged, versatile, high strength and low-weight
- Beaver – Grade 100 Chain carries markings '10' stamped along its entire length for easy identification
- Sizes available from 6 - 32mm

Beaver – Winner Grade 100 Lifting Chain – to AS 2321

Load Rated – Sizes 6 - 32mm

Code	W.L.L Tonne	Nominal Size mm	S mm	R Pitch mm	F Outside Width mm	Finish	UOM	Metres Per 100(kg)
WIN6	1.40	6	6	18	21.6	Painted	Metre	104
WIN8	2.50	8	8	24	28.8	Painted	Metre	64
WIN10	4.00	10	10	30	36.0	Painted	Metre	40
WIN13	6.70	13	13	39	46.8	Painted	Metre	24
WIN16	10.00	16	16	48	57.6	Painted	Metre	15.9
WIN20	16.00	20	20	62	70.5	Painted	Metre	11.2
WIN22	19.00	22	22	66	79.2	Painted	Metre	8.2
WIN26	26.50	26	26	78	94.1	Painted	Metre	6.18
WIN32	40.00	32	32	96	107.0	Painted	Metre	4.15

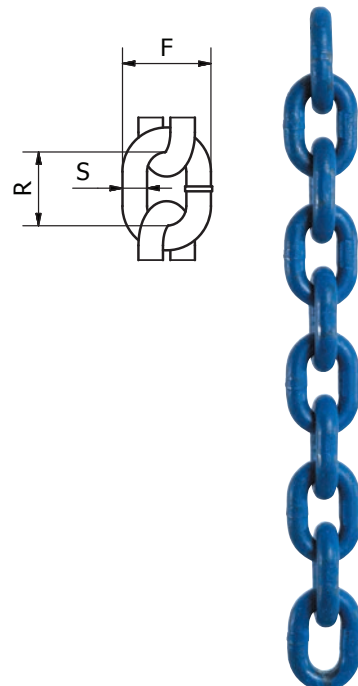

Metres per drum are subject to + or - 10% on actual metreage



BEAVER HEAVY DUTY PLASTIC CHAIN



Beaver heavy duty plastic chain, is available in a range of colours to suit your application.

Beaver Light-weight Long Link Plastic Chain

Supplied in 50 metre spooled reels – Sizes 6mm only

Code	Size mm G	Size mm L	Size mm W	Size mm I	Size mm S	UOM	Colour
131006BY	6	38	20	26.8	8	Metre	Black/Yellow
131006RW	6	38	20	26.8	8	Metre	Red/White

NOT TO BE USED FOR LIFTING

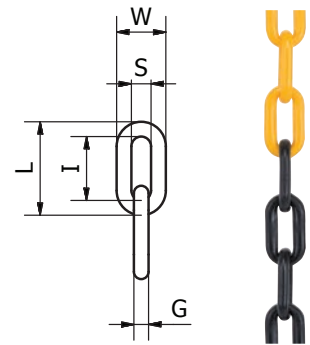

BEAVER CALIBRATED LOAD CHAIN

Beaver Calibrated Hand Chain

Zinc – Size 5mm only / To suit Chain Block & Geared Girder Trolley

Code	Nominal Size mm	Finish	Size mm S	Size mm R	Size mm F	UOM	KG Per Metre
150005W	5	Zinc	5	23.5	18	Metre	0.5

Metres per drum are subject to + or - 10% on actual metrage

NOT TO BE USED FOR LIFTING

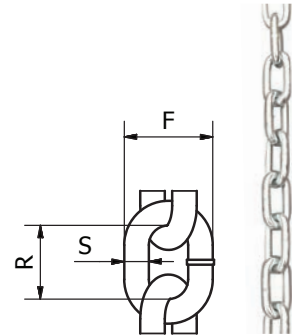

Beaver Calibrated Roller Door Chain

Zinc Dichromate – Size 5mm only

Code	Nominal Size mm	Finish	Size mm S	Size mm R	Size mm F	UOM	KG Per Metre
149405	5	Zinc Dichromate	5	28.8	21.8	Metre	0.5

Metres per drum are subject to + or - 10% on actual metrage

NOT TO BE USED FOR LIFTING

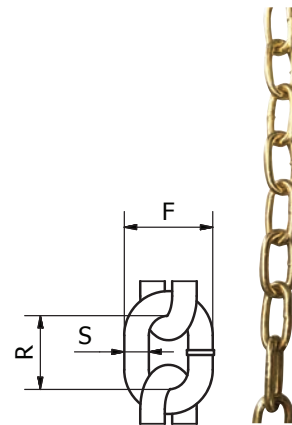

Beaver Calibrated Load Chain - Grade 80

To suit Beaver 3G Chain & Lever Blocks

Code	Dia x Inside Length mm	KG Per Metre	Finish	UOM
149005	5.0 x 15	0.6	Black	Metre
149006	6.0 x 18	0.8	Black	Metre
149007	7.0 x 21	1	Black	Metre
149008	8.0 x 24	1.42	Black	Metre
149010	10 x 30	2.2	Black	Metre

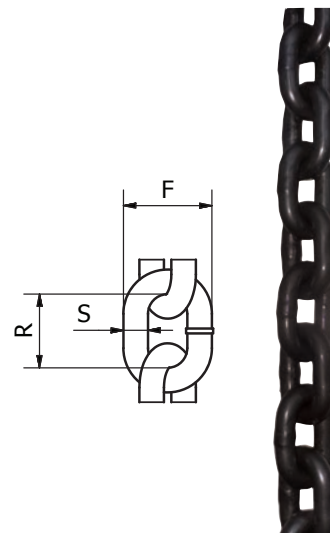

NOT TO BE USED FOR LIFTING



PRODUCT REFERENCE GUIDE

Part Number	Page Number
100103	5
100104	5
100105	5
100106	5
100108	5
100110	5
100113	5
100116	5
100120	5
100124	5
100303	4
100304	4
100305	4
100306	4
100308	4
100310	4
100313	4
100316	4
100320	4
100324	4
130104	7
130105	7
130106	7
130108	7
130110	7
130205	7
130206	7
130208	7
130304	7
130305	7
130306	7
130308	7
130310	7
130411	16

Part Number	Page Number
142008	12
142010	12
142013	12
143106	10
143108	10
143110	10
143306	10
143308	10
143310	10
143313	10
143316	10
143320	10
145006	14
145007	14
145008	14
145010	14
145013	14
146102	8
146104	8
146106	8
146108	8
146206	9
146208	9
147104	8
147106	8
147108	8
147110	8
148006	15
148007	15
148008	15
148010	15
148013	15
148016	15
148020	15

Part Number	Page Number
148022	15
148026	15
148032	15
149005	19
149006	19
149007	19
149008	19
149010	19
149405	19
100103PP	6
100104PP	6
100105PP	6
100106PP	6
100108PP	6
100110PP	6
100113PP	6
100203PP	6
100303PP	6
100304PP	6
100305PP	6
100304-VTC-AC	5
100206-2.5	5
100206-1.2	5
130206-2.5	5
130308-1.5	5
130206-1.5	5
100306PP	6
100308PP	6
100310PP	6
100313PP	6
131006BY	18
131006RW	18
142008G	12
142010G	12

Part Number	Page Number
142013G	12
143313A	11
143316A	11
146102L	9
150005W	19
WIN6	17
WIN8	17
WIN10	17
WIN13	17
WIN16	17
WIN20	17
WIN22	17
WIN26	17
WIN32	17
WOX5	13
WOX7	13
WOX10	13
WOX13	13

TESTED AND COMMERCIAL CHAIN

TESTED AND COMMERCIAL CHAIN

SECTION

1

NOTES



NOTES

1

SECTION

TESTED AND COMMERCIAL CHAIN



**NATIONAL HEAD OFFICE
NEW SOUTH WALES**

Email: sydneysales@beaver.com.au
National Sales: 1300 783 606
Phone: (02) 8882 5700
Fax: (02) 8882 5899

55 Sarah Andrews Close
Erskine Park NSW 2759
PO Box 5001
St Clair NSW 2759

WESTERN AUSTRALIA

Email: perthsales@beaver.com.au
Ph: (02) 8882 5700

VICTORIA/ TASMANIA

Email: melbournesales@beaver.com.au
Ph: (02) 8882 5700

**SOUTH AUSTRALIA/
NORTHERN TERRITORY**

Email: adelaidesales@beaver.com.au
Ph: (08) 8244 3555
Fax: (08) 8244 3533

QUEENSLAND

Email: brisbanesales@beaver.com.au
Ph: (07) 3279 1100
Fax: (07) 3279 1381

www.beaver.com.au